

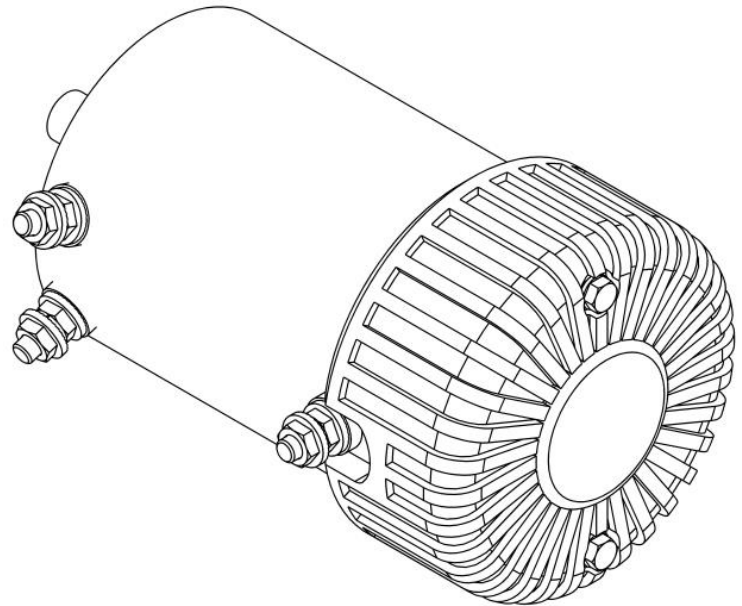

TIGER SHARK
18000/18000SR/15000/15000SR
REPLACEMENT MOTOR



PART NUMBER:

90-42646



**SAVE THESE
INSTRUCTIONS**

CONTENTS

| ITEM | QUANTITY | DESCRIPTION |
|------|----------|----------------|
| 1 | 1 | MOTOR |
| 2 | 1 | ROLLER BEARING |

ANTI-SEIZE LUBRICANT MUST BE USED ON ALL STAINLESS STEEL FASTENERS TO PREVENT THREAD DAMAGE AND GALLING

ITEM 1

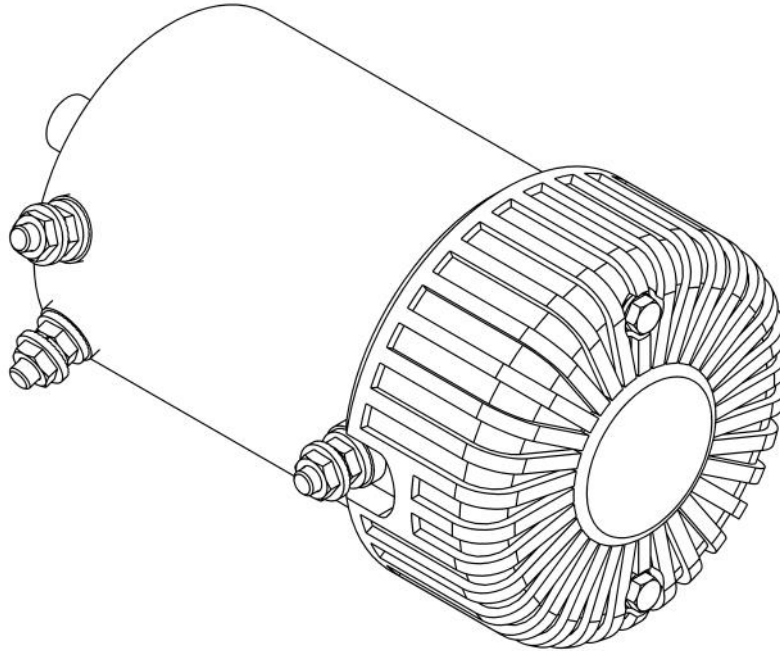

ITEM 2

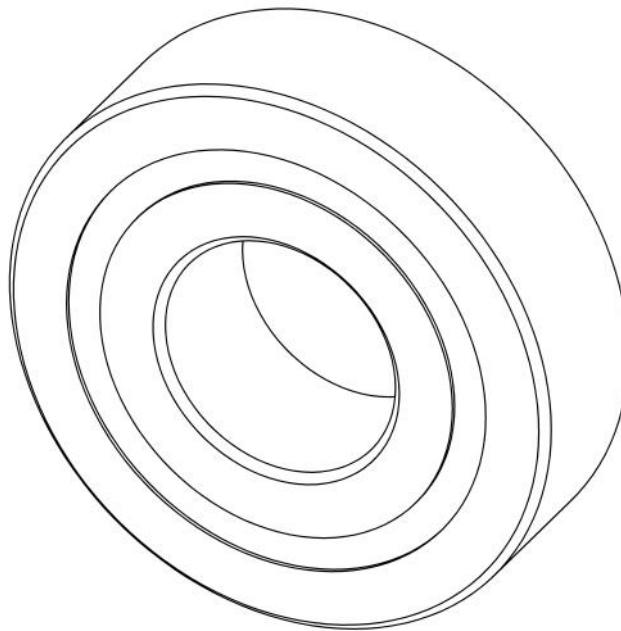

INSTALLATION INSTRUCTIONS

1. Remove contents from box, verify if all parts listed are present and free from damage. **Failure to identify damage before installation could lead to a rejection of any claim.**
2. Carefully read and understand all instructions before attempting installation. **Ensure that all mounting hardware is torqued to specifications prior to use.**
3. Disconnect the power cable and ground cable from the battery.
4. Remove one M8 serrated flange nut from each motor terminal and remove the original motor cables .
5. Remove the control box by removing the two bolts holding it in place. See **Figure 1**.
6. Remove the two motor bolts. See **Figure 2**.

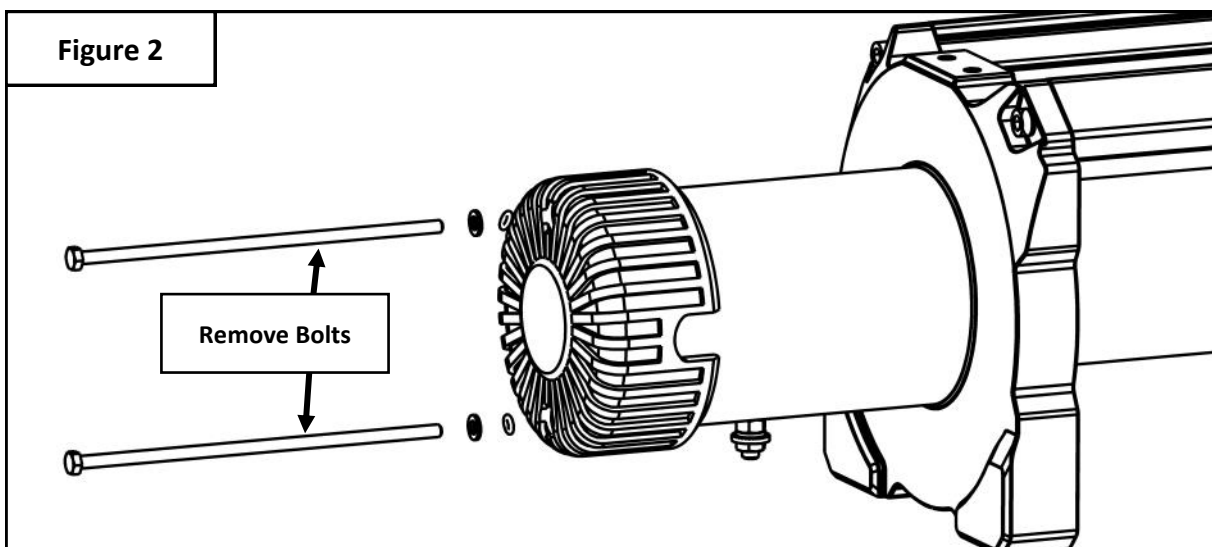
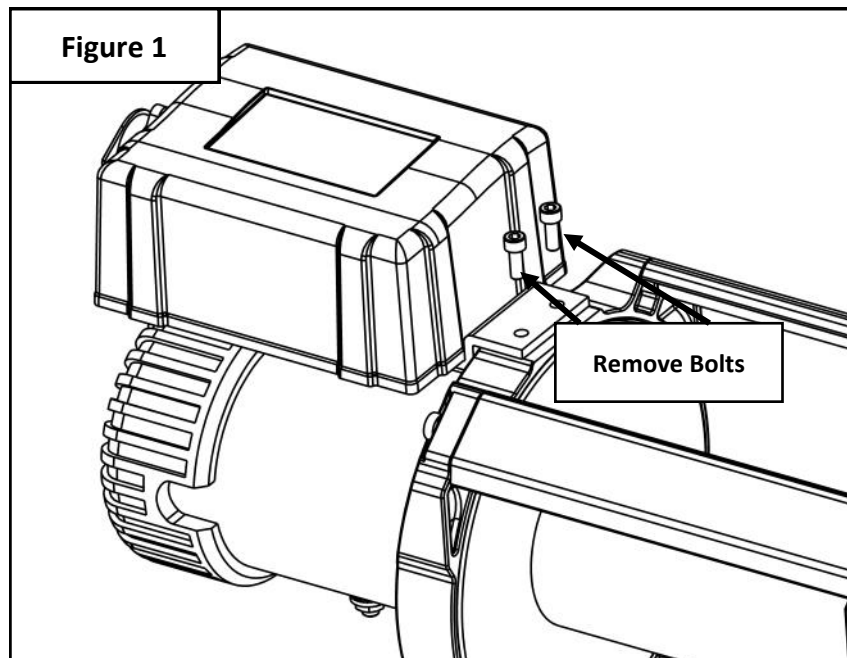

- 7. Remove the motor from the drum support. See **Figure 3**.
- 8. Remove the two bolts from the Tie Bar. See **Figure 4**.

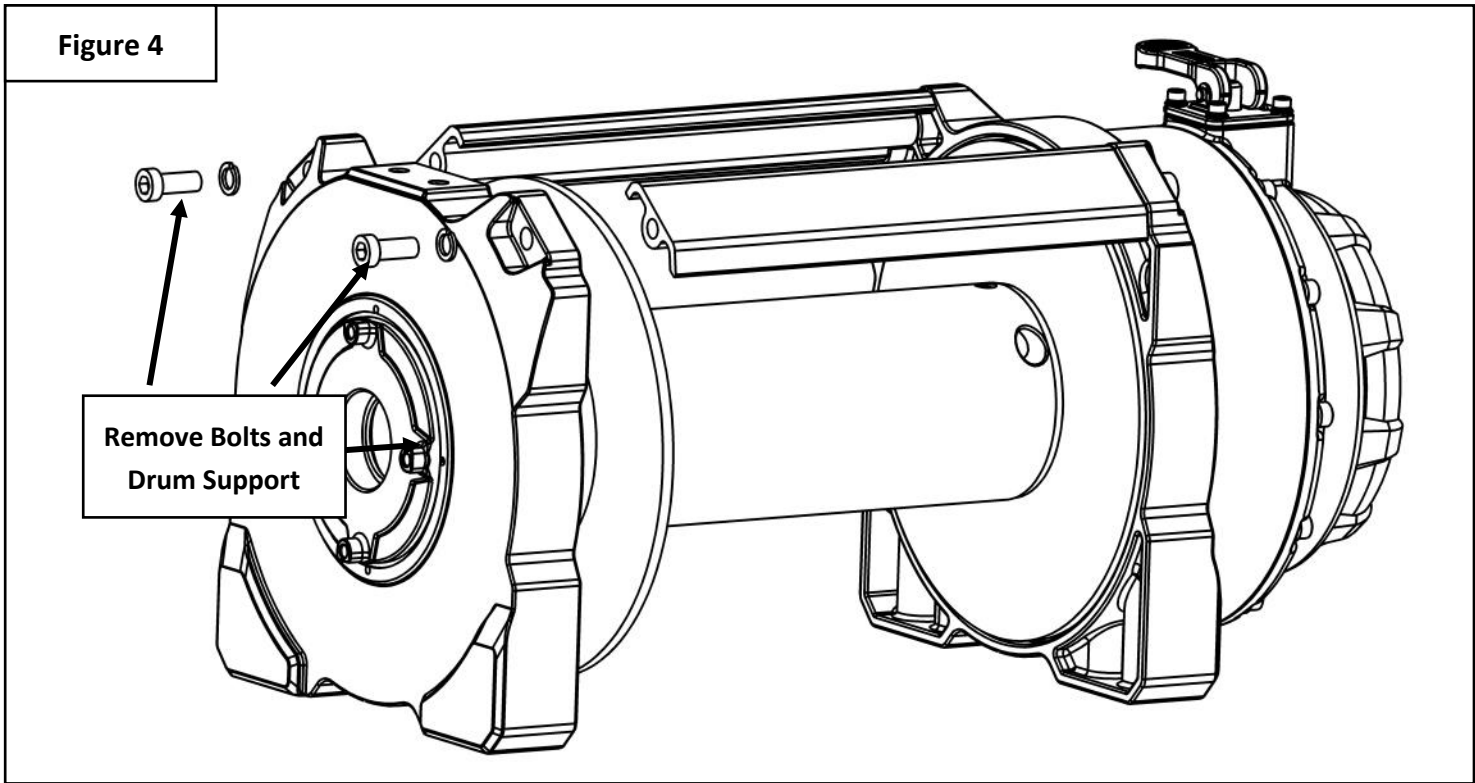
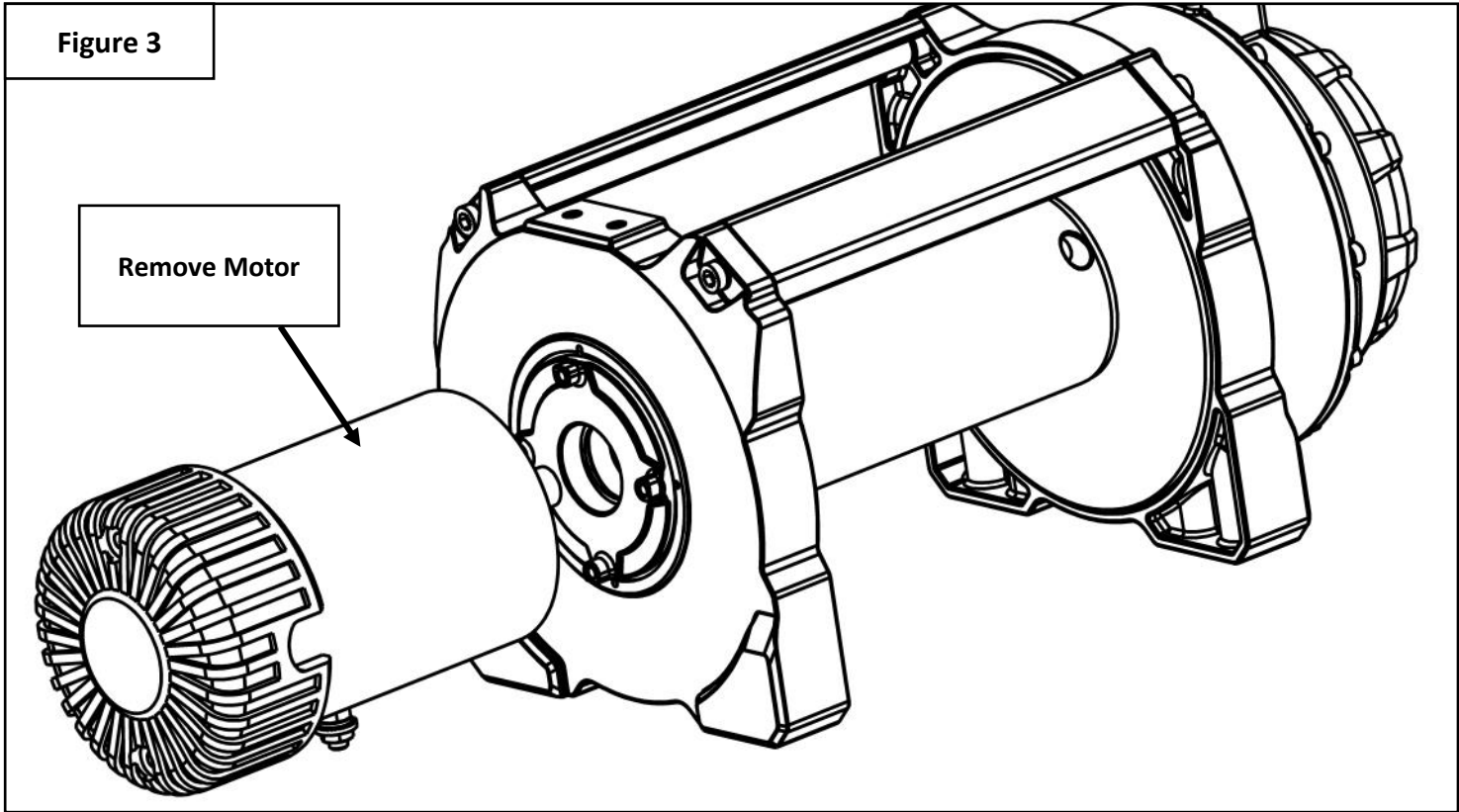

9. Remove the roller bearing from the motor drum support and replace it with the new Roller Bearing (**item 2**). See **Figure 5**.
10. Reinstall the motor drum support onto the winch.
11. Install the replacement Motor (**item 1**) onto the winch.

Figure 5

Remove Motor
Roller Bearing

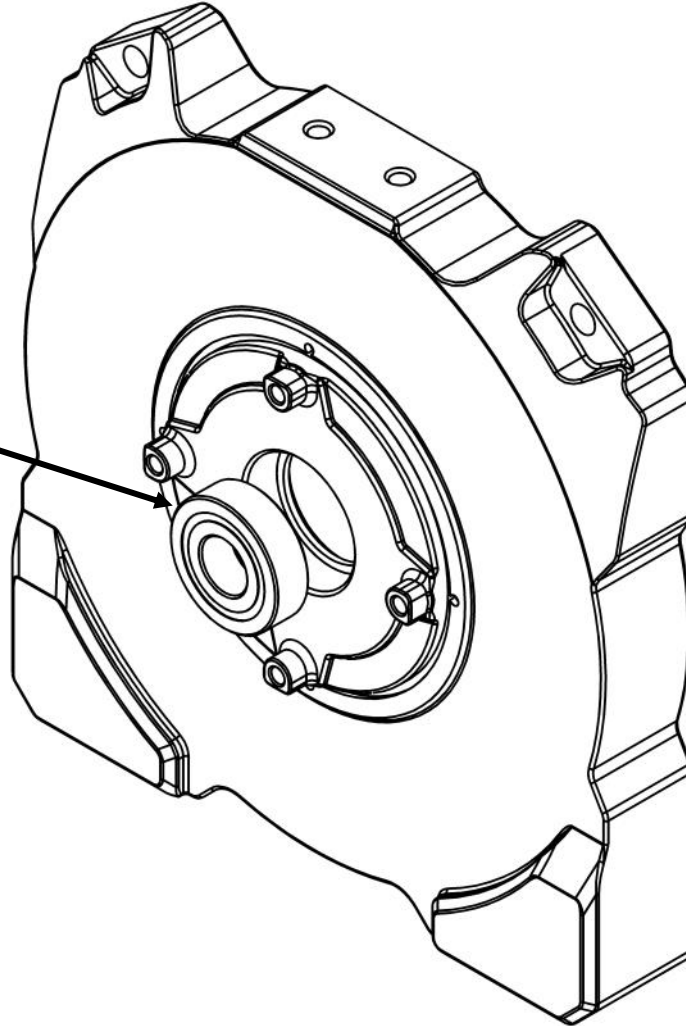

12. Reuse the hardware that was removed and install the control box onto the winch. See **Figure 6**.

13. Connect the red, black, yellow, and ground cables to the motor. See **Figure 7**.

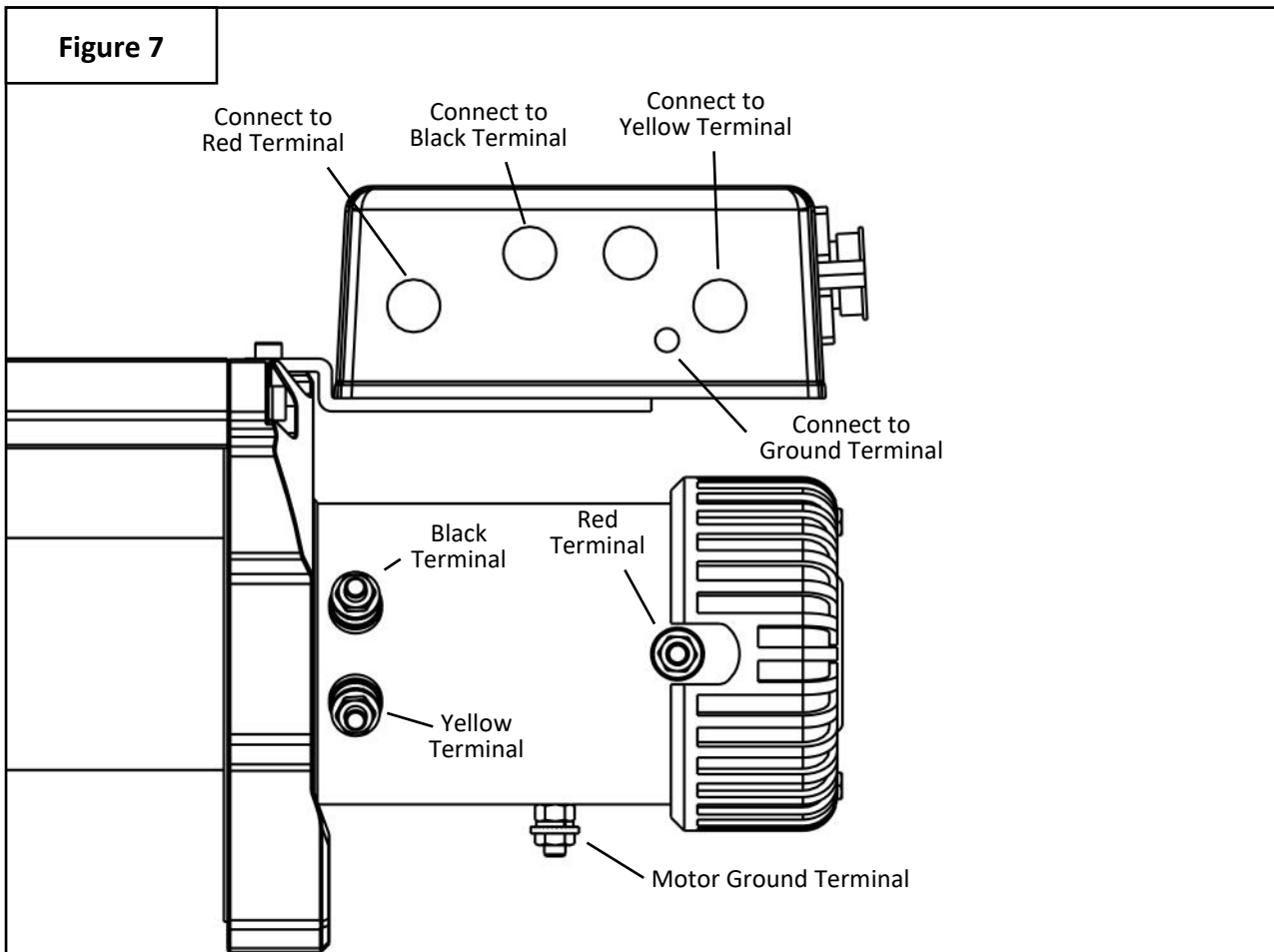
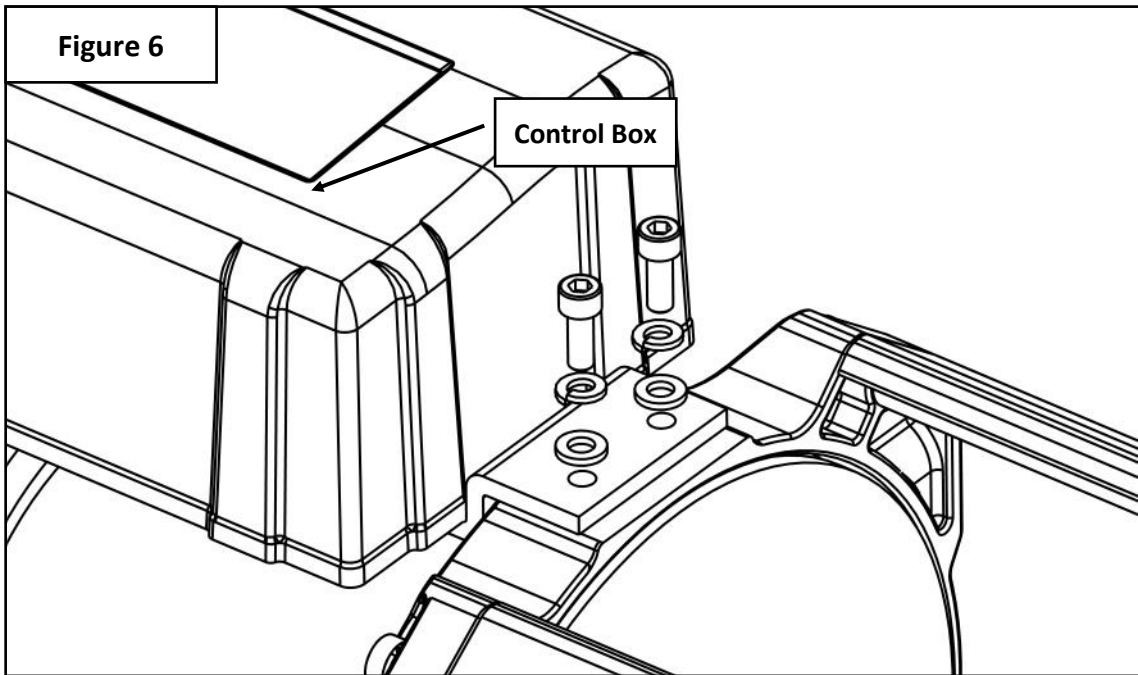

Failure to follow these instructions could lead to death, personal injury, and / or property damage.

FASTENERS:

All SUPERWINCH supplied fasteners must be utilized and installed in accordance with the installation instructions and apply torque to the specifications as defined. DOUBLE CHECK ALL FASTENERS BEFORE INITIAL USE, AND PERIODICALLY IN THE FUTURE TO ENSURE PROPER FUNCTION AND SAFETY.

EYE PROTECTION:

ALWAYS WEAR SAFETY GLASSES OR GOGGLES DURING THE INSTALLATION PROCESS TO AVOID PERSONAL INJURY.

FOR CALIFORNIA RESIDENTS ONLY-PROP 65 WARNING:

Some products may contain chemicals such as DEHP, which can cause cancer, birth defects or other reproductive harm. For more info go to www.p65warnings.ca.gov



For more information on this and other products,
or to be put in contact with a Superwinch sales
rep or distributor, call (800) 323- 2031
or email info@superwinch.com

SUPERWINCH
320 W. COVINA BLVD.
SAN DIMAS, CA 91773

© 2019 SUPERWINCH®, Superwinch®, and S Superwinch® (design) are registered trademarks of Superwinch Inc. in the United States and/or other countries.