



SX10/10SR/12/12SR REPLACEMENT CONTROL BOX



PART NUMBER:

90-42642



**SAVE THESE
INSTRUCTIONS**

CONTENTS

ITEM	QUANTITY	DESCRIPTION
1	1	CONTROL BOX
2	4	M5 BUTTON HEAD BOLT
3	4	M4 SELF -TAPPING SCREW

ANTI-SEIZE LUBRICANT MUST BE USED ON ALL STAINLESS STEEL FASTENERS TO PREVENT THREAD DAMAGE AND GALLING

INSTALLATION INSTRUCTIONS

1. Remove contents from box, verify if all parts listed are present and free from damage. **Failure to identify damage before installation could lead to a rejection of any claim.**
 2. Carefully read and understand all instructions before attempting installation. **Ensure that all mounting hardware is torqued to specifications prior to use.**
-
3. Disconnect the power cable and ground cable from the battery.
 4. Remove one M8 serrated flange nut from each motor terminal. See **Figure 1**.
 5. Remove the original motor cables from the red, yellow, and blue motor terminals. See **Figure 1**.
 6. Remove the original control box ground cable from the motor ground terminal. Do not remove the battery ground cable from the motor. See **Figure 1**.
 7. Remove the original control box by removing the four button head bolts holding it in place. See **Figure 2**.

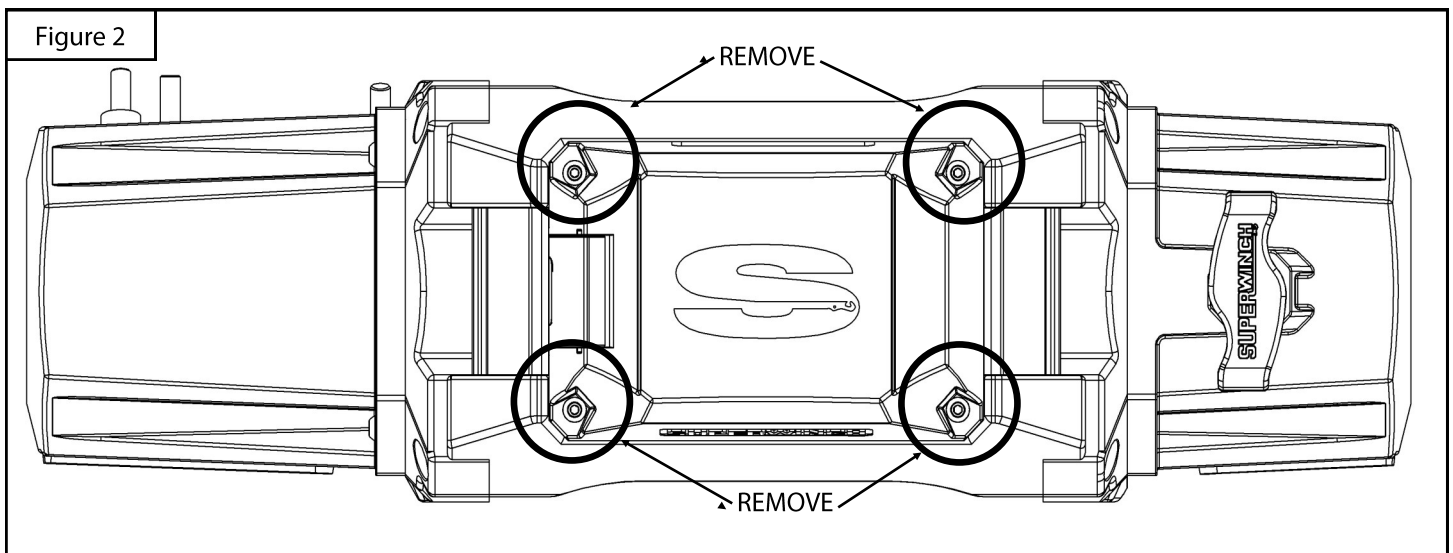
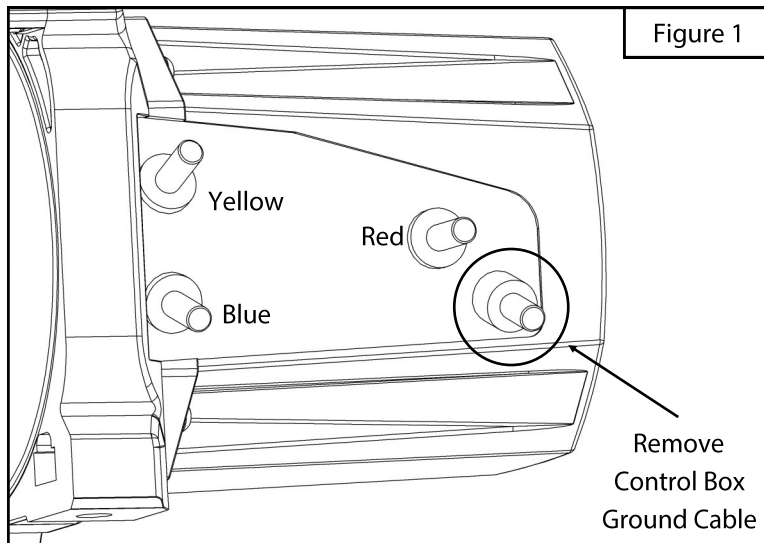

8. Disconnect the drum light wiring harness. See **Figure 3**.

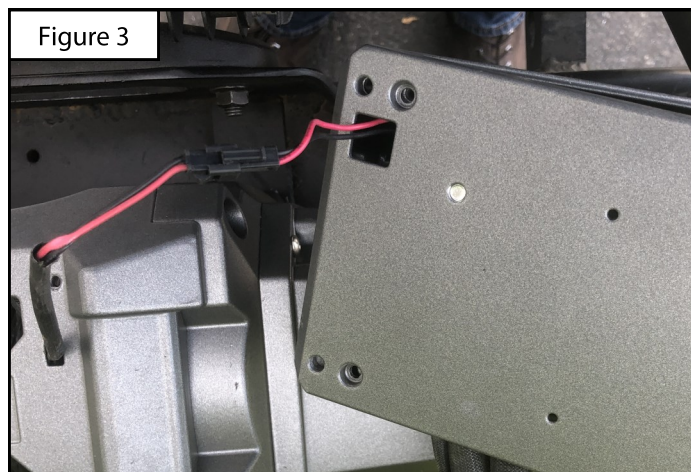

9. Use the M8 serrated flange nuts removed in **step 4** to attach the motor cables on the replacement control box to the motor terminals making sure to match the color of the motor terminal to the color of the motor cable.
10. Use the last M8 serrated flange nut removed in **step 4** to attach the control box ground cable on the replacement control box to the motor ground terminal. Make sure that the battery ground cable is still in place.
11. Connect the drum light wiring harness on the replacement control box.
12. Fasten the replacement control box to the winch using the M5 button head bolts.

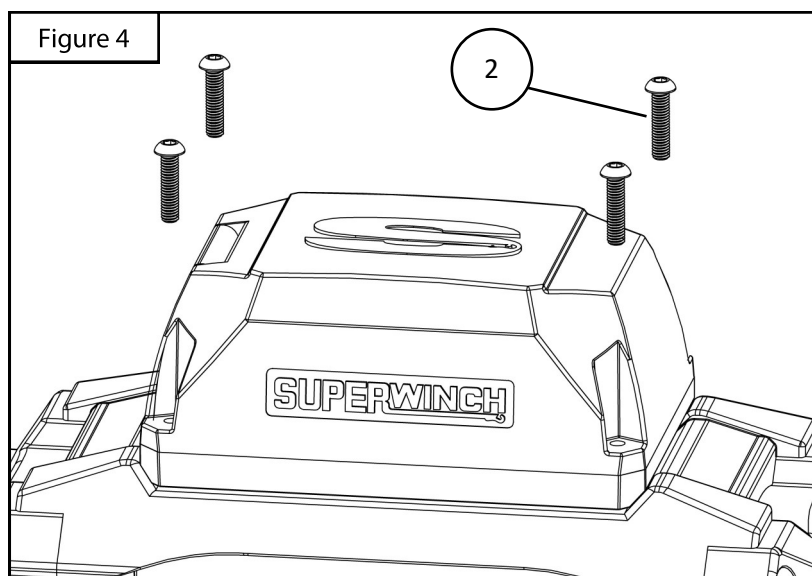

13. If the control box is remote mounted off of the winch, follow the steps below.

- Before installing the replacement control box, remove the bottom plate from the control box. See **Figure 5**.
- Cut the zip-tie retaining the drum light wire bundle. See **Figure 6**.
- Route drum wiring through the back of the replacement control box.
- Re-install the bottom plate to the control box.
- Follow **steps 3-6**.
- Remove the original control box by removing the 4 screws on the corners.
- Follow **steps 8-11**.
- Fasten the replacement control box to the mounting surface using the M4 selftapping screws. See **Figure 7**.

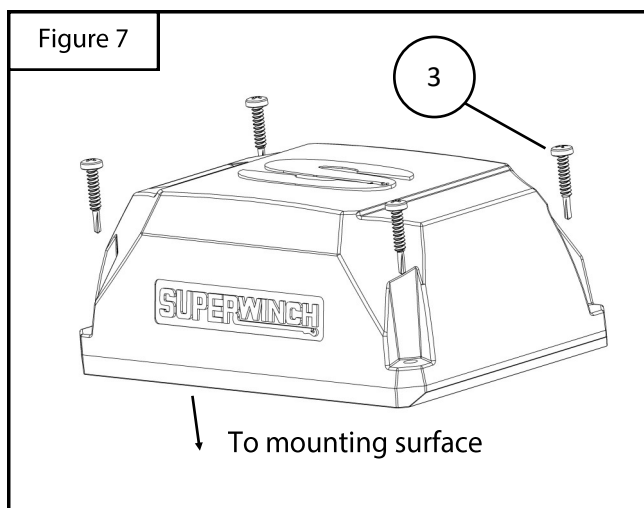
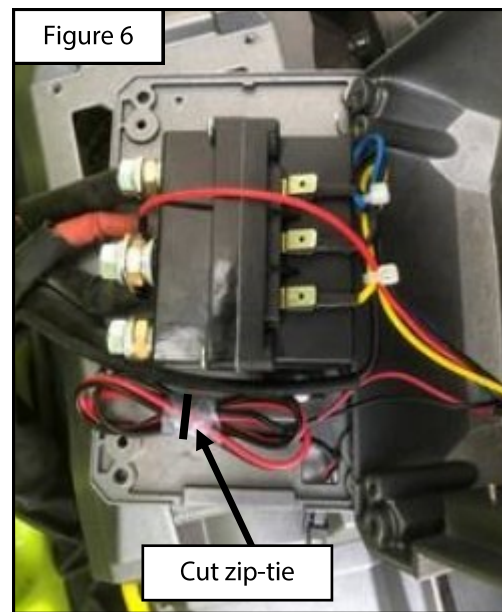
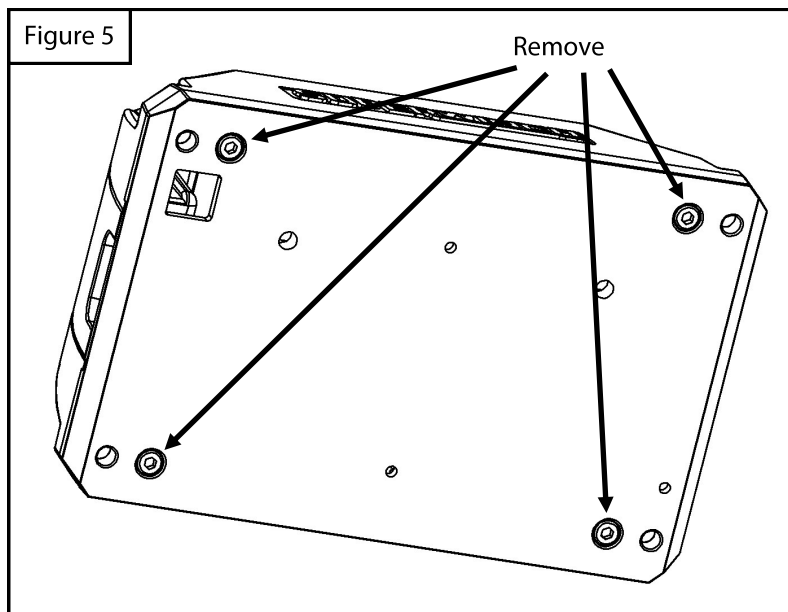

14. Connect the power cable and ground cable to the battery.

WARNINGS

Failure to follow these instructions could lead to death, personal injury, and / or property damage.

FASTENERS:

All SUPERWINCH supplied fasteners must be utilized and installed in accordance with the installation instructions and apply torque to the specifications as defined. DOUBLE CHECK ALL FASTENERS BEFORE INITIAL USE, AND PERIODICALLY IN THE FUTURE TO ENSURE PROPER FUNCTION AND SAFETY.

EYE PROTECTION:

ALWAYS WEAR SAFETY GLASSES OR GOGGLES DURING THE INSTALLATION PROCESS TO AVOID PERSONAL INJURY.

FOR CALIFORNIA RESIDENTS ONLY-PROP 65 WARNING:

Some products may contain chemicals such as DEHP, which can cause cancer, birth defects or other reproductive harm. For more info go to www.p65warnings.ca.gov



For more information on this and other products,
or to be put in contact with a Superwinch sales
rep or distributor, call (800) 323- 2031
or email info@superwinch.com

SUPERWINCH
320 W. COVINA BLVD.
SAN DIMAS, CA 91773

© 2019 SUPERWINCH®, Superwinch®, and S Superwinch® (design) are registered trademarks of Superwinch Inc. in the United States and/or other countries.